

# AB Fence Engineering Manual

Complete Engineering Details For The  
Allan Block Fence System

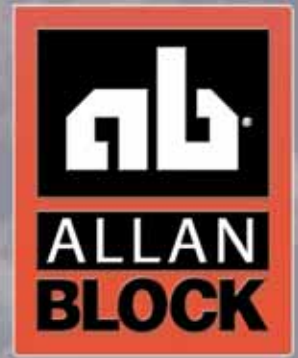

[allanblock.com](http://allanblock.com)

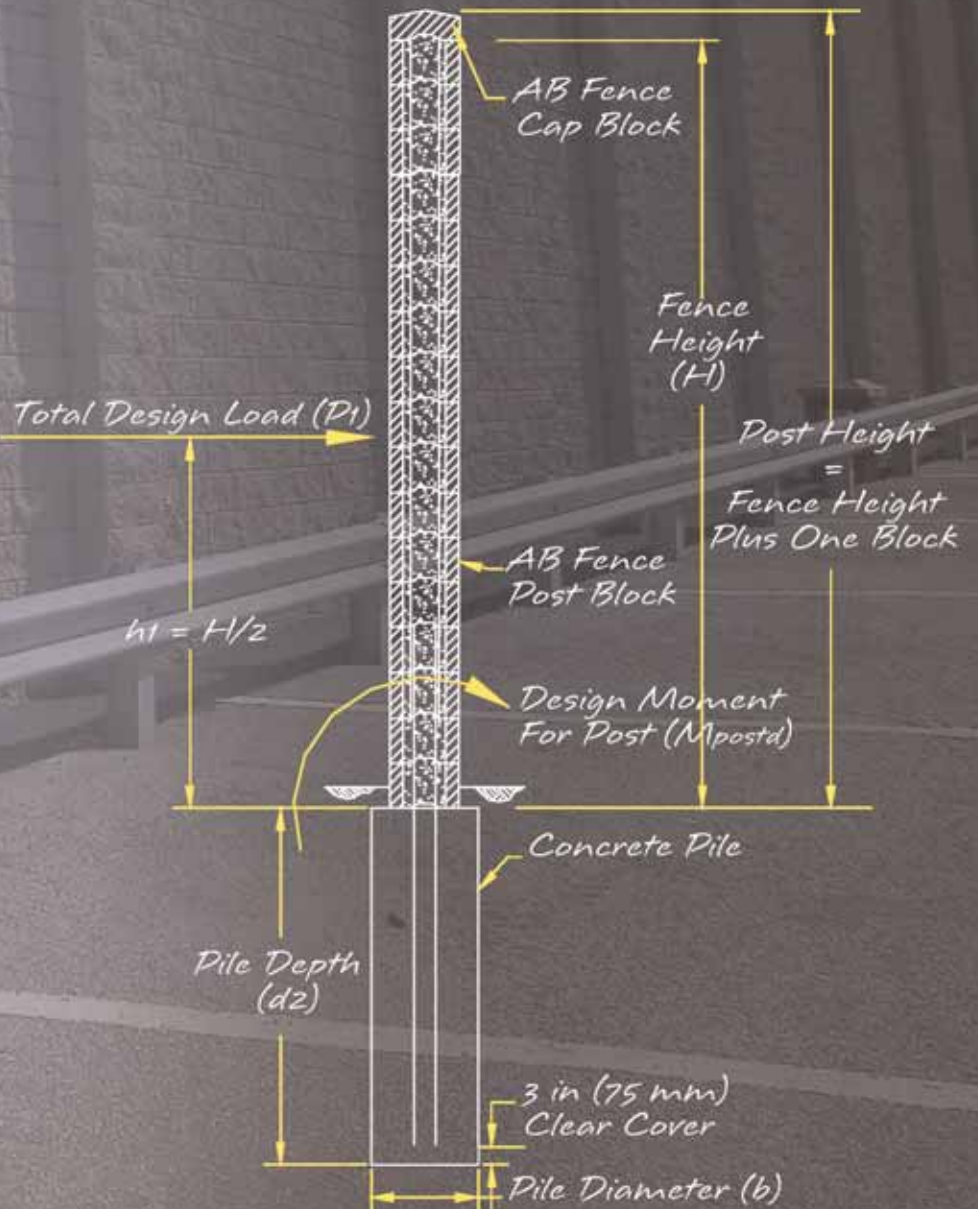



## ***FOREWORD***

This manual represents the techniques used by Allan Block® in our engineering practice to design the AB Fence™, a fencing and sound barrier system. It is not intended as an engineering textbook. The methods we use have evolved over the course of twenty years and continue to do so as our knowledge and experience grows.

The intended users of this manual are practicing engineers. We assume that the reader is already familiar with the basic principles of structural design of concrete systems. We encourage others to contract a qualified engineer for assistance with the design of similar structures. The example problems in this manual pertain only to the design and construction of the AB Fence™ System.

### ***AB® Post Block***



The AB Fence Post block is the primary structural component of the system. Integrated into reinforced concrete piles, the AB Fence post forms the backbone of the AB Fence system.

### ***AB® Panel Block***



The AB Fence Panel block is stacked between the rigid post structures. The interlocking design of the panel block creates a strong, solid barrier that easily transfers wind and seismic loads to the post structures while remaining flexible enough in the dry-stacked units to absorb wind loads.

### ***AB® Fence Cap***



The AB Fence Cap is used to finish the top of the post and panels. The crowned configuration provides aesthetic appeal, and channels water away from the posts and panel.

### ***AB® Corner Unit***



The AB Fence Corners are manufactured for 90° transitions.

### ***AB® Half Panel and AB® Lite Panel Blocks***

The AB Fence Half Panel blocks are manufactured to eliminate the need for in-the-field producing of half size panel block by cutting standard panel blocks. (not available in all locations)



AB Lite Panel



AB Half Panel



# TABLE OF CONTENTS

## Chapter One - Concepts & Definitions

• Wind Loads .....	1
• Measuring the Wind .....	1
• Wind Pressures .....	2
• Exposure Effects .....	3
• System Configuration .....	4
• Panel Configuration .....	5
• System Selfweight .....	6
• Flexibility and Strength .....	6
• Post Configuration .....	8
• Footing Configuration .....	8

## Chapter Two - AB Fence Engineering Methodology

• Terminology .....	9
• Design Example .....	11
<i>Allan Block Fence Parameters</i> .....	11
<i>Compressive Strength Calculations</i> .....	15
<i>Tensile Strength Calculations</i> .....	18
<i>Concrete Shear Calculations</i> .....	19
<i>Footing Design</i> .....	20
• Soil Retention .....	21
• Soil Retention with Geogrid Reinforced Mass .....	22
• Appendix 1 .....	23
<i>Intermediate Columns</i> .....	23
<i>Unreinforced Leveling Pad</i> .....	23
• References .....	24



# ***LIST OF FIGURES & TABLES***

## **Chapter One - Concepts & Definitions**

### **FIGURES**

Figure 1	Typical Weather Vane and Anemometer .....	1
Figure 2	Tributary Area Per Post .....	4
Figure 3	Typical Panel Elevation .....	4
Figure 4	Typical Bond Beam .....	4
Figure 5	Fence Post Structure .....	4
Figure 6	Typical Panel Elevation .....	5
Figure 7	Dry Stacked Interlock .....	5
Figure 8	Selfweight Resisting Movement .....	6
Figure 9	Work Energy Free Body Diagram .....	6
Figure 10	Possible Shear Failure Diagram .....	7
Figure 11	Post Core After Testing and Demolition .....	8

### **TABLES**

Table 1.1	Unit Conversions .....	2
Table 1.2	Wind Speed Verses Wind Pressure .....	2
Table 1.3	Pressure Coefficient .....	3
Table 1.4	Design Wind Speeds and Stagnation Pressures .....	7

## **Appendix 1 - Intermediate Column & Other Constructability Enhancements**

Figure 12	Intermediate Columns .....	23
Figure 13	Unreinforced Concrete Leveling Pad .....	23



# **CHAPTER ONE**

## ***Concepts and Definitions***

### ***Wind Loads***

The AB Fence™ System is designed to provide screening, security and noise abatement. It is based on a simple concept of post, panel and footing construction. The panels absorb the wind loads and transfer applied loads to the rigid post structures. The post structures then transfer the loads into a below grade footing. These three structural elements of the AB Fence System must be adequately designed to withstand the applied forces. An added benefit to the system is that while the panels are rigid enough to transfer loads they are free-floating in the notches of the post. This allows the panels to flex up and down due to frost heaves or minor site settlements. As with other fencing structures the primary overturning force comes from the wind. The following will discuss the ways wind is measured and how pressure is applied.

### ***Measuring the Wind***

The wind can vary both in terms of its speed and its direction. As a result different pieces of equipment are needed to measure these different characteristics. Wind direction is commonly determined by weather vanes or wind socks which will swing around and show which direction the wind is blowing from.

The main instrument used to measure the speed of the wind is an anemometer. The little cups on a typical anemometer (Figure 1) catch the wind and spin around at different speeds according to the strength of the wind. A recording device is used to count how many times they spin around in a given amount of time. Positioning the anemometer properly to accurately record the wind speeds is important and there are detailed standards that must be followed.



**Figure 1:**  
**Typical Weather Vane  
and Anemometer**

Wind conditions have been measured for years and the information provided in local design codes is based on decades of recorded data. By analyzing this data the average wind speed with a given return period can be obtained for a region. The "return period" refers to the most probable average wind speed that will be equaled or exceeded once during a period of time compared to the life of the fence. Thus, a shorter return period would provide lower wind speed. Longer return periods would increase the probability for higher wind speeds. For example, a 10-year average velocity will be much less than a 50-year average velocity. Allan Block has set the return period for the AB Fence Design methodology to 50 years.

## Wind Pressures

The wind speed can be used to calculate a wind pressure using the Bernoulli Equation relating velocities to pressures. Since wind is air in motion the resulting wind pressures are related to its kinetic energy and can be determined by the following expression:

$$q = (\gamma) \left( \frac{V^2}{(2)(g)} \right) \text{ where,}$$

$q$  is wind pressure in lb/ft<sup>2</sup> or N/m<sup>2</sup> (pascal)  
 $\gamma$  is specific weight of air in lb/ft<sup>3</sup> or kg/m<sup>3</sup>  
 $g$  is gravitation force in ft/sec<sup>2</sup> or m/sec<sup>2</sup>  
 and  $V$  is the average wind speed in ft/sec or m/sec

$q$  is more commonly seen in the following form:

$$q = \frac{1}{2} \rho V^2 \quad \text{where,}$$

$q$  is wind pressure in lb/ft<sup>2</sup> or N/m<sup>2</sup> (pascal)  
 $\rho$  is an average air density - 0.0809 lb/ft<sup>3</sup> or 1.29 kg/m<sup>3</sup>  
 and  $V$  is the average wind speed in ft/sec or m/sec

Further simplifying gives:

$$q = (x)(V^2) \quad \text{where,}$$

$x$  is the unit conversion, based on which velocity units the designer is using, see Table 1.1

This is called the "**stagnation pressure**" or total pressure because it refers to the maximum positive increase over ambient pressure that can be exerted on the fence by any given wind speed. Stagnation pressure is the basic, non-factored pressure to which all other pressures are referred to and are usually referenced in regional building codes.

TABLE 1.1

Unit Conversions		
V	x	Yields
ft/sec	0.00119	PSF
m/sec	0.00064645	kPa
mph	0.00256	PSF
km/hr	0.0004807	kPa

Table 1.2 provides a few stagnation pressures computed from the given wind speeds. If the 50-year return period velocity is equal to the wind speed in Table 1.2, the tabulated values for wind pressure can be used in your design.

TABLE 1.2

Wind Speed Verses Wind Pressure								
Wind Speed (V)	mph	60	70	80	90	100	110	120
	km/hr	96	113	129	145	161	177	193
Wind Pressure (q)	psf	9.3	12.6	16.4	20.8	25.6	31.0	36.9
	kPa	0.443	0.603	0.785	0.995	1.23	1.48	1.77

## Exposure Effects

Wind pressures exerted on the AB Fence depend not only on the speed of the wind, but on the interaction of exposure effects as well. Any structure, including but not limited to, buildings, landscape features, general topography, and open areas such as fields, parks, parking lots, street corridors, and bodies of water all significantly affect the wind patterns and need to be considered. An exposure category that adequately reflects the characteristics of ground surface irregularities is determined for the site. Open terrain allows for the maximum exposure, while fences found in developed or urban areas have minimum exposure. Described below are the three exposure categories used in the designs of the AB Fence:

- **Exposure B:** Surface roughness consisting of urban and suburban areas, wooded areas, or other terrain with numerous closely spaced obstructions having the size of a single family dwelling or larger.
- **Exposure C:** Surface roughness consisting of open terrain with scattered obstructions having heights generally less than 30 ft (9.1 m) extending ½-mile (805 m) or more from the site. This category includes flat open country, grasslands, and bodies of water under 1-mile (1,609 m) in width.
- **Exposure D:** Describes the most severe exposure with surface roughness consisting of flat, unobstructed areas and bodies of water over 1-mile (1,609 m) in width. Exposure D extends inland from the shoreline ¼-mile (402 m).

Additionally, calculations should also include site topography and structural importance when factoring wind pressures on a structure. These AB Pressure Coefficients are listed in Table 1.3 by the exposure category, but also account for general site topography, structure height and structural importance as well.

Again, for AB Fence designs the wind pressure is based on the 50-year average wind speed. The pressure should be multiplied by the appropriate Pressure Coefficient to determine a factored pressure. This factored pressure is then used in the design calculations.

Table 1.3

Pressure Coefficient		
Exposure	H<12ft (3.7m) Pressure Coefficient	H>12ft (3.7m) Pressure Coefficient
B	0.68	0.85
C	0.9	1.2
D	1.25	1.5

## System Configuration

Allan Block Fence is designed to resist laterally applied pressures, specifically the pressure applied by wind. The system resists pressures by distributing the applied forces to the systems structural elements. The elements of the system are made up of the posts, bond beams, dry-stacked panel block and concrete pile footings (Figure 2). The height and width of a single panel makes up the **tributary area** of which each element must be designed.

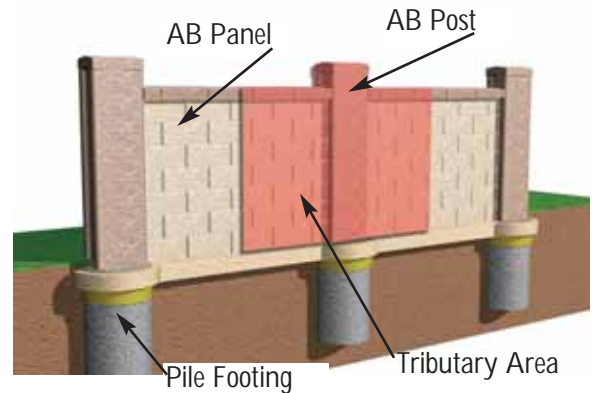

Figure 2:  
Tributary Area Per Post

The **panel** (Figure 3) is made up of dry-stacked panel block and **bond beams**. Bond Beams are dry-stacked panel block combined with horizontal and vertical steel which are cast solid with a fine sand-mix concrete grout meeting design strength requirements (Figure 4). Typically there is a bond beam at the top and the bottom of each panel. Intermediate bond beams are added as needed, depending upon the design height and length of the panel.

The fully constructed panel acts to transfer the applied pressure to the main structural element, the **post** (Figure 5). The post is made up of individually stacked post block combined with vertical steel and cast solid with a standard concrete mix meeting design strength requirements. The vertical steel reinforcement is lap spliced with footing dowels to transfer the applied overturning forces into the footing structure. The **footing** structure can be a variety of different types ranging from a simple shallow pile footing, to a very complex designed deep caisson.

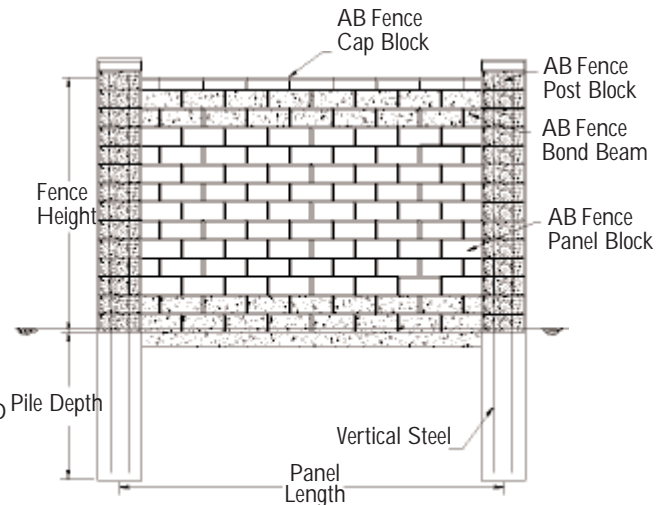

Figure 3:  
Typical Panel Elevation

A site specific evaluation along with the magnitude of the structure will allow the engineer to choose the appropriate footing type. This document includes a simple pile footing, which will cover the majority of AB Fence projects.

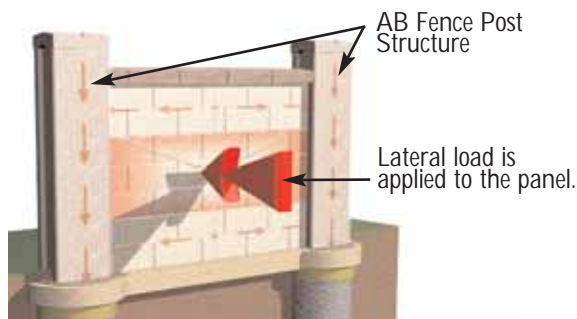

Figure 5:  
Fence Post Structure

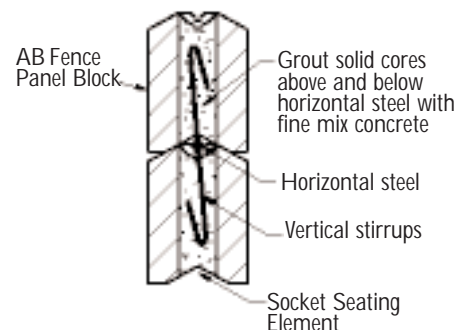

Figure 4:  
Typical Bond Beam

## Panel Configuration

The panel's dry-stacked units and bond beams work in unison to both resist the applied wind pressure and distribute these forces to the structural posts. Figure 6 shows a typical AB Fence Panel cross section. Each panel block has a unique ball and socket configuration which when stacked in a running bond pattern, interlock together to form a semi-rigid panel. The interlocking strength is due to the selfweight of the block above pushing down on each course. The lowest courses within a panel have the most interlocking strength due to the greater selfweight from above. Figure 7 illustrates the flexing of a panel under extreme loading and how selfweight helps to resist bulging. In order for bulging to occur in the panel, the locking forces within the ball and socket joint of the dry-stacked units must literally lift the courses of block above the bulge. The selfweight of these courses enhances the strength and rigidity of the panel and continues to increase as you move lower in the panel.

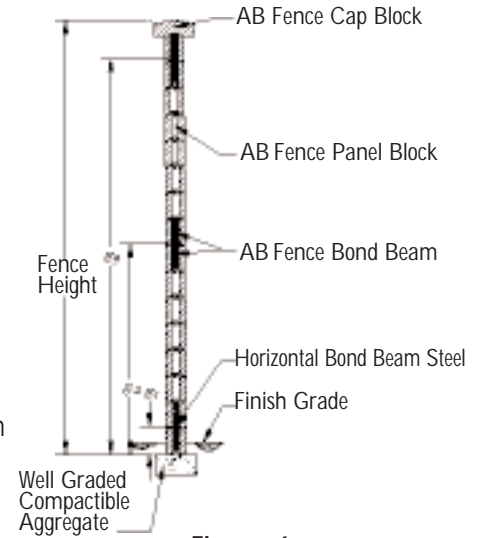

Figure 6:  
Typical Panel Section

The bond beams are made using two courses of individual panel block with a single #4 (10M) reinforcing bar cast between the courses. The cores are cast solid with a fine sand-mix concrete grout and vertical stirrups are placed in every other block core to add shear strength to the bond beam (see Figure 4). The composite nature of the bond beam and the dry-stacked unit's ball and socket is what allows the panel to perform at such a high level.

As the panel is stressed by the applied wind loads the bond beam and dry-stacked block are subject to minor deflections. These minor deflections engage the bond beam's steel and the interlock of the ball and socket. Which causes an increase in ultimate panel capacity. Individual bond beam test results have consistently shown that it acts exactly like a monolithic reinforced beam and has much higher actual moment capacities than are used in a simple design calculation.

By combining the natural strength of the composite bond beam with the strength the ball and socket configuration brings to the system, a designer can show an increase in the capacity of the individual bond beams during calculations. Allan Block suggests the addition of a conservative 1.5 multiplier to the calculated bond beam capacity to account for the rigidity of the ball and socket. See Chapter Two for this concept shown in calculation.

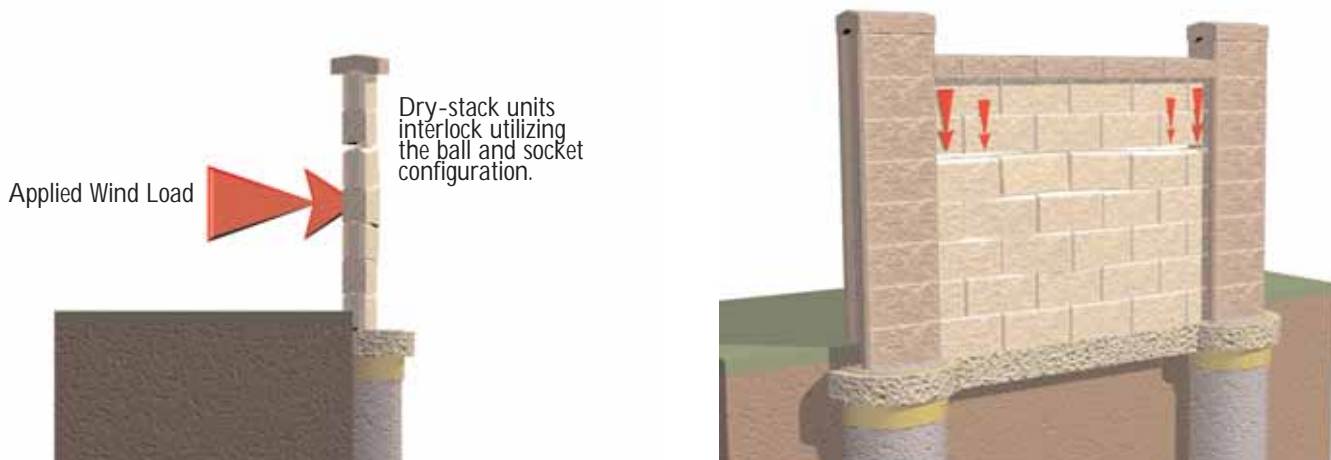

Figure 7 Dry Stacked Interlock

## System Selfweight

The AB Fence System has many advantages since it is a concrete masonry system. It provides superior durability and low maintenance, but also provides weight similar to a gravity retaining wall. The weight of the system when combined with its eccentricity ( $e$ ) creates a moment ( $m$ ) that needs to be overcome before any applied force can actually engage the flexural steel (Figure 8). Concrete masonry products have a significant selfweight of roughly 135 pcf (2162.5 kg/m<sup>3</sup>). The design engineer can utilize the inherent resistance of the selfweight to reduce the applied moments at the base of the post. The design engineer can choose to ignore the value of the systems selfweight but by doing so they are treating this concrete system the same as a light weight wooden fence. This manual will utilize 90% of the calculated selfweight resistance in all design examples.

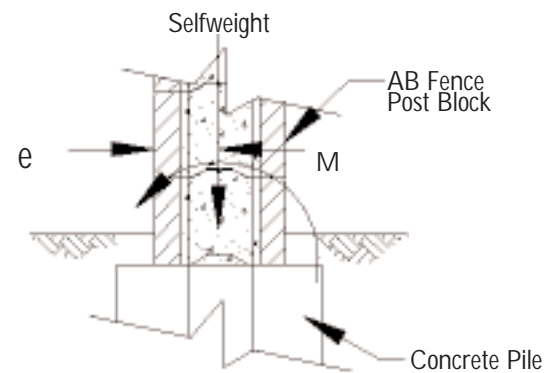

Figure 8:  
Selfweight Resisting Movement

## Flexibility and Strength

The benefit of the dry-stacked units does not end with simply added flexural strength. The more intriguing capability of the dry-stacked units within the assembled panel is their ability to dissipate and distribute applied forces. This ability was first observed in the full-scale panel testing Allan Block and the University of Calgary completed in 2003, where the applied force did not equal the forces received at the post structures. In fact, they were considerably less. Further investigation and testing showed that the simple static engineering law of "force in equals force out" did not hold true to the AB Fence Panel using dry-stacked units, which have a large selfweight and a ball and socket configuration. The AB Fence Panel configuration brings a dynamic variable to the static equation. This dynamic variable can best be described as Work Energy.

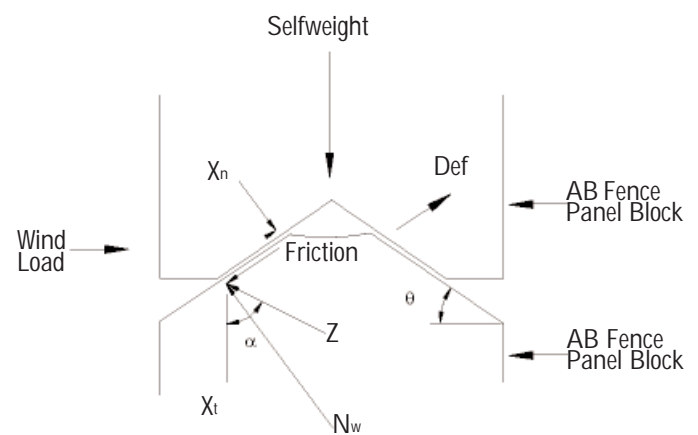

Figure 9:  
Work Energy Free-Body Diagram

Work Energy is defined as a force (wind) acting upon an object (the panel block's ball and socket joint) causing a displacement (Figure 9). In the Allan Block Fence panel there are two forms of work energy being developed, external work and internal work. First is the external work, which is simply the deflection of the entire panel due to the wind force. However, because the Panel is free to move within the Post notch, there is no friction to overcome.

The second form of Work Energy occurs internally in the ball and socket joint. As the wind load is applied, the running bond of the dry stacked block try to deflect away from the force laterally, but the socket resists any deflection due to its natural conical locking configuration. The selfweight of all the courses above a particular socket joint provides the downward force. This selfweight force serves to stiffen the joint. Thus, the lower the joint is within the panel the greater the internal resisting forces within that joint or socket. Therefore, most of the deflection within the panel occurs toward the top of the panel where the selfweight is less.

The internal work occurs when the applied force becomes great enough to overcome the frictional interaction within the socket which results in a deflection. There are two forms of deflection that could occur. The first is a purely horizontal translation, but this could only occur if the bottom tension edge of the panel block were to shear off horizontally allowing the socket to release (Figure 10).

This form of deflection never occurred in any of the full-scale tests performed due to the internal strength of each block, 3000 psi (20.7 MPa) min. The shear strength of a block is directly related to its compression strength, therefore the stronger the block the more resistant to shear failures and the stronger the ball and socket can become.

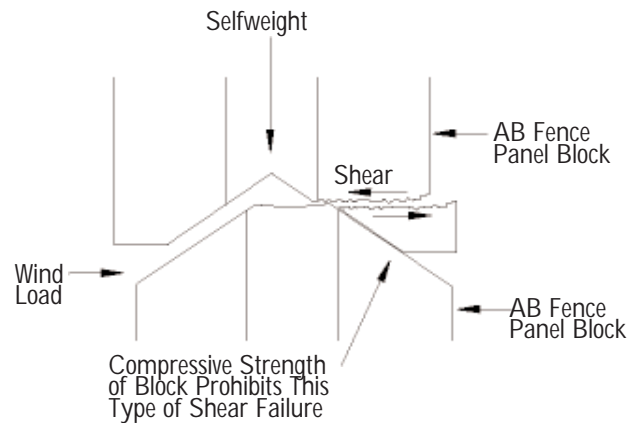

Figure 10:  
Possible Shear Failure Diagram

The second form of deflection, which did occur during testing, was a movement along the natural sloped plane of the socket which provided displacement in an upward and lateral direction (variable  $X_i$  in Figure 9). Each movement when it occurred was very small because the pressure within the socket would release and the frictional interaction would once again be greater than the applied load. Once the force was built up enough to overcome the internal resisting forces another deflection would occur. Each time an internal deflection occurred a certain amount of force was absorbed into the joint causing a reduction of applied forces to the posts.

The results showed that at low pressures the loads received at each post are quite small. The lowest recorded test value was 28% of the applied load. This is due to the large number of dry-stacked joints within the panel that had the ability to shift or deflect early on. At higher pressures the number of joints having the ability to adjust decreases because movement has already occurred making the joint more rigid, which causes the percentage of force received by each post to increase. The result of the Work Energy effect is an absorption of the applied loads. When this occurs the applied moments to the post structures are also reduced. This allows the designer to increase the tributary area by increasing the post spacing. The net result is a smaller number of posts and footings required, and a reduced cost for a project. In calculation, this Work Energy effect is represented as an increase to the posts calculated capacity.

Table 1.4 represents the recommended post capacity increase to reflect the Work Energy findings based on the test results. These post capacity increases will be used in the design example in Chapter Two.

Table 1.4

Design Wind Speeds and Stagnation Pressures								
Miles Per Hour (kph)	mph	60	70	80	90	100	110	120
	km/hr	96	113	129	145	161	177	193
Unfactored Pressure lb/ft <sup>2</sup> (kPa)	psf	9.3	12.6	16.4	20.8	25.6	31.0	36.9
	kpa	0.443	0.603	0.785	0.995	1.23	1.48	1.77
Percentage Increase to Design Capacity For Post Design								
	% *	1.50	1.50	1.45	1.35	1.30	1.20	1.10
* Percent values are a conservative increase based on test results								

## Post Configuration

The AB Fence Post is a fully tested structural column assembly that has repeatedly shown ultimate capacities similar to those of a monolithic reinforced concrete post. The post block has a unique conical shaped core that when stacked with additional courses forms a serrated shaped interior core of concrete. Figure 11 shows the core of the AB Fence Post after flexural testing and demolition to remove the AB Fence Post masonry material. To remove the masonry material, an electric jack hammer was required. This unique shaped interior adds to the incredible bonding effect the dry-cast block have with the wet-cast concrete core which enhances the monolithic nature of the post system. The testing results have proven that the full masonry composite section should be used in design applications. Therefore, first principle beam capacity equations utilizing the full composite section of the post will be used throughout this manual along with the suggested capacity increase percentages from Table 1.4



Figure 11: Post Core After Testing and Demolition

## Footing Configuration

The stabilizing foundation to the entire AB Fence System is a reinforced concrete footing. Footings can be designed in many different styles but they all are designed to resist the lateral and vertical applied forces. The typical AB Fence footing is a 2 ft (600mm) diameter concrete pile footing directly under the post drilled to a design depth with simple vertical steel reinforcement. The site specific parameters such as soil strength and wind loading will determine the design size and depth of each shaft. The vertical pile footing reinforcement should be designed to match the vertical steel within the post structure and be extended out of the top of the footing to splice with the post reinforcement. By increasing the pile footings diameter and or depth, the capacity of the footing can be increased.

This manual will follow standard calculations for non-constrained concrete pile footings. However, design engineers can choose to design their own type or style of footing by determining the overturning moments at the base of the AB Fence Post. The Allan Block Fence system will work with any type of foundation system which will adequately handle the overturning moments such as a complex Drilled Shaft, spread footing or cantilever footing.



## CHAPTER TWO

# AB Fence Engineering Methodology

This chapter will provide an explanation of engineering principals, terminology and methodologies used in the design of the AB Fence system.

### Terminology

Ab	= Area of steel for one reinforcing bar in the Post
A <sub>bb</sub>	= Area of steel reinforcing bar in the Bond Beam
As	= Total Area of steel in the Post
Aw	= The thickness of the Post Block wing
A <sub>wpanel</sub>	= Area of Panel section only
b	= Diameter of Footing
b <sub>bb</sub>	= Bond Beam section length used for Bond Beam capacity calculations = (2)(h)
bs	= Post section length used for Post capacity calculations = $Pl - (2)(Pnd)$
Ce	= Wind Force Coefficient based on exposure and height
clr	= Spacing between nub and bottom of Post Block notch
d	= Calculated depth of footing
d <sub>2</sub>	= Estimated depth of footing
d <sub>bb</sub>	= Distance to tension steel in the Bond Beam
ds	= Distance to tension steel in the Post
Em	= Modulus of Elasticity of masonry
Es	= Modulus of Elasticity of nonprestressing steel
Fa	= Active Earth Pressure
Fah	= Horizontal Force Vector of Active Earth Pressure
Fq	= Surcharge Force
Fqh	= Horizontal Force Vector of Surcharge Force
fb	= Allowable Compressive Strength of masonry
fm	= Compressive Strength of concrete
fs	= Allowable Tensile Stress of reinforcing steel = (0.4)(fy)
fy	= Yield Stress of reinforcing steel
h	= Course Height
h <sub>1</sub>	= Distance in feet from ground surface to point of applied load
H	= Total Panel height from footing to top of cap
Hs	= Retained height of soil
j	= j and k are coefficients used for internal moment and definitions of the neutral axis of the Post
j <sub>bb</sub>	= j <sub>bb</sub> and k <sub>bb</sub> are coefficients used for internal moment and definitions of the neutral axis of the Bond Beam
k	= j and k are coefficients used for internal moment and definitions of the neutral axis of the Post
k <sub>bb</sub>	= j <sub>bb</sub> and k <sub>bb</sub> are coefficients used for internal moment and definitions of the neutral axis of the Bond Beam
K <sub>a</sub>	= Lateral Earth Pressure Coefficient

## Terminology

$M_{postd}$	= Applied Moment to Post = $(P)(Ta)(H / 2)$
$M_{paneld}$	= Applied Moment to Bond Beam = $(P)(Ta)\{PS / [(8)(N_{bb})]\}$
$MC_{bb}$	= Allowable Moment Capacity of Bond Beam based on the masonry compressive strength
$M_{cp}$	= Allowable Moment Capacity of Post based on the masonry compressive strength
$M_{footing\ design}$	= Total Moment used to design Footing = $M_1$ - selfweight moment for the Post, Panel and Footing
$M_{t_{bb}}$	= Allowable Moment Capacity of Bond Beam based on the Tensile Stress of the reinforcement
$M_{tp}$	= Allowable Moment Capacity of Post based on the Tensile Stress of the reinforcement
$M_{swfooting}$	= Total resistance Moment due to the selfweight of the Footing
$M_{swpanel}$	= Total resistance Moment due to the selfweight of the Panel
$M_{swpost}$	= Total resistance Moment due to the selfweight of the Post
$M_{post\ design}$	= Total Moment used to design Post = $M_{postd} - M_{swpanel} - M_{swpost}$
$M_{ah}$	= Overturning Moment due to Soil Retention
$M_{qh}$	= Overturning Moment due to Surcharge force
$n$	= Modular Ratio and is calculated using the Modulus of Elasticity of the composite materials
$N_{bb}$	= Number of Bond Beams in a Panel
$n_l$	= Nub Length
$P$	= Design Wind Pressure = $(qs)(C_e)$
$P_1$	= The footing's design moment translated into its Force Vector
$P_d$	= Post Block Depth
$P_{er}$	= Work Energy Factor
$PH$	= Total Post Height from footing to top of cap
$P_l$	= Post Block Length
$P_{nd}$	= Post Block Notch Depth
$P_s$	= Post Spacing from Center to Center of Posts
$qs$	= Unfactored wind pressure
$q$	= Surcharge Force in Soil retention calculations
$\rho$	= Steel to Concrete ratio in the Post
$\rho_{bb}$	= Steel to Concrete ratio in the Bond Beam
$r$	= radius of the reinforcing bars in a structural member
$s$	= Number of Panel Block long panel used for post spacing
$S_{actored}$	= Allowable lateral soil-bearing pressure based on a depth of 1/3 the depth of embedment
$S_{ssa}$	= Allowable Shear Stress for reinforced structures
$S_{req}$	= Calculated Shear Stress at the base of the Post
$S_{wing}$	= Allowable Shear Stress on the Post wing
$S_{wreq}$	= Total Shear Stress on the Post wing
$t$	= Panel Block Depth
$T_a$	= $(P_s)(H)$ = Tributary Area of panel from center to center of Posts
$w$	= Panel Block Length
$w_c$	= Unit Weight of Concrete = 135 pcf (2162.5 kg/m <sup>3</sup> )
$w_{t_{cap}}$	= Weight of Cap unit
$w_{t_{panel}}$	= Weight of Panel Block
$w_{t_{panelq}}$	= Weight of grout per Panel Block
$w_{t_{post}}$	= Weight of Post Block
$w_{t_{postc}}$	= Weight of grout per Post Block
$Z_{panel}$	= Number of block course in a Panel
$Z_{post}$	= Number of block course in a Post
$\phi_i$	= Internal Friction Angle of soil
$\phi_{wi}$	= Weighted Internal Friction Angle of soil
$\beta$	= Wall Batter
$\gamma_i$	= Unit Weight of Soil

## Design Example

To start a design there is typically a total length and desired height of fence shown on the site plan documents. The length can be divided into equal segments to get a rough starting post spacing. The post spacing of an AB Fence should be based on the modular lengths of the individual panel block to minimize cutting and speed construction. The designer should maximize post spacing to minimize project costs. For detailed instructions on installation see the AB Fence Installation Guide.

### Allan Block Fence Parameters:

Course height (h)	= 7.625 in (194 mm)
Panel Block depth (t)	= 5.628 in (143 mm)
Panel Block length (w)	= 17.625 in (448 mm)
Post Block depth (Pd)	= 11.625 in (295 mm)
Post Block length (Pl)	= 17.625 in (448 mm)
Post Block Notch depth (Pnd)	= 1.5 in (38 mm)
Nub length (nl)	= 0.1875 in (5 mm)
Clear space between nub and bottom of post notch (clr)	= 0.25 in (6 mm)

### Example:

Fence Parameters: Allan Block recommends that all AB Fence projects be built with castellated fence posts. These are posts that are at least one block taller than the panel to allow for panel movement.

Fence length	= 175 ft (53.34 m)
Average height	= 7.5 ft (2.29 m)
Basic Wind Speed	= 80 mph (129 kph) - (Table 1.4)
Unfactored Pressure (qs)	= 16.4 psf (785.2 N/m <sup>2</sup> ) - (Table 1.4)
Exposure Type	= B - (Table 1.3)
Exposure Coefficient (Cf)	= 0.68 - (Table 1.3)
# of Bond Beams (N <sub>bb</sub> )	= 2 (1 - #4 (10M) each)
Size and # of bars in Post	= 4 - #5 (15M)
Work Energy Factor (Per)	= 1.45 - (Table 1.4)

NOTE: no soil retention required in this example, for soil retention calculations see pages 21-22.

For this example we will equally divide the total length of Fence into equal sized panels. The designer may want to simply calculate the maximum panel spacing.

Rough post spacing = 174 ft / 12 panels = 14.5 ft ≈ 9 panel block

Therefore: Each post spacing is made up of (s) number of Panel Blocks = 9

$$Ps = (s)(w) + (2)(nl+clr) - (2)(Pnd) + (2)(Pl/2)$$

$$Ps = 14.51 \text{ ft (4.42m)}$$

Height of Panel (H):

$$Z_{\text{panel}} = 12 \text{ course}$$

$$H = (Z_{\text{panel}} - 1)(h) + 7.16 \text{ in} + 4.75 \text{ in}$$

$$= 7.98 \text{ ft (2.43 m)}$$

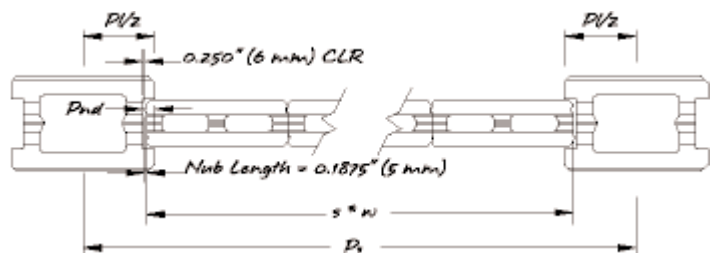

## Design Example

Height of Post (H):

$$Z_{\text{post}} = 13 \text{ course (Castellated = 1 more than panel)}$$

$$PH = (Z_{\text{post}})(h) + 4.75 \text{ in} = 8.66 \text{ ft (2.64 m)}$$

Tributary Area (Ta):

$$Ta = (Ps)(H)$$

$$= 115.825 \text{ ft}^2 (10.76 \text{ m}^2)$$

Calculate the Velocity Pressure:

$$qs = (\frac{1}{2})(\rho)(V^2) = (0.00256)(V^2)$$

$$= 16.4 \text{ psf (785.2 N/m}^2)$$

Design Pressure(P):

$$P = (qs)(Ce)$$

$$= (16.4 \text{ psf})(0.68) = 11.15 \text{ psf (534 N/m}^2)$$

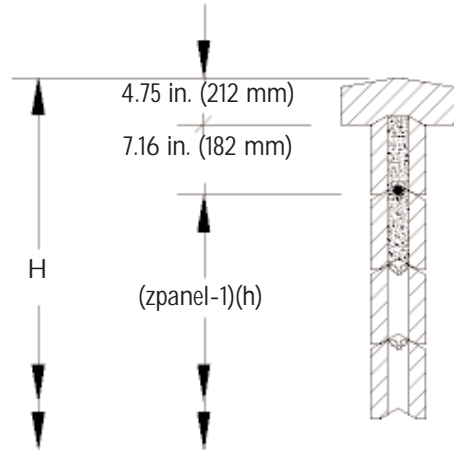

Applied Design Moments: The following moment equations are from standard engineering principles.

Post: Cantilever Beam - Uniformly Distributed Load

$$M_{\text{postd}} = (P)(Ta)(H / 2)$$

$$= (11.15 \text{ psf})(115.825 \text{ ft}^2)(7.98 \text{ ft} / 2)$$

$$= 5154.1 \text{ lb-ft (6988 N-m)}$$

NOTE: This Post Moment will be reduced by using the influence of selfweight in the next section.

$$M_{\text{paneld}} = \frac{(P)(Ta)(Ps)}{(8)(N_{bb})}$$

Panel: Simple Beam - Uniformly Distributed Load

$$= \frac{(11.15 \text{ psf})(115.825 \text{ ft}^2)(14.51 \text{ ft})}{(8)(2)}$$

$$= 1171.25 \text{ lb-ft (1588 N-m)}$$

NOTE: The AB Fence Bond Beam and Post capacities must be greater than this applied value.

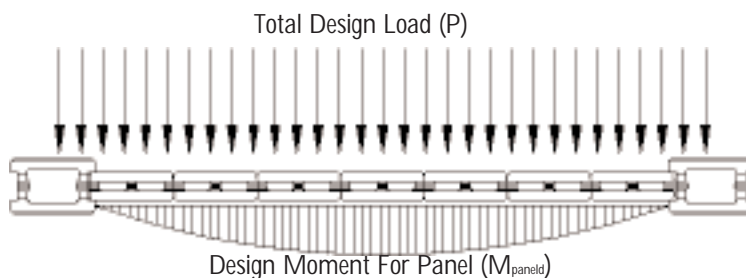
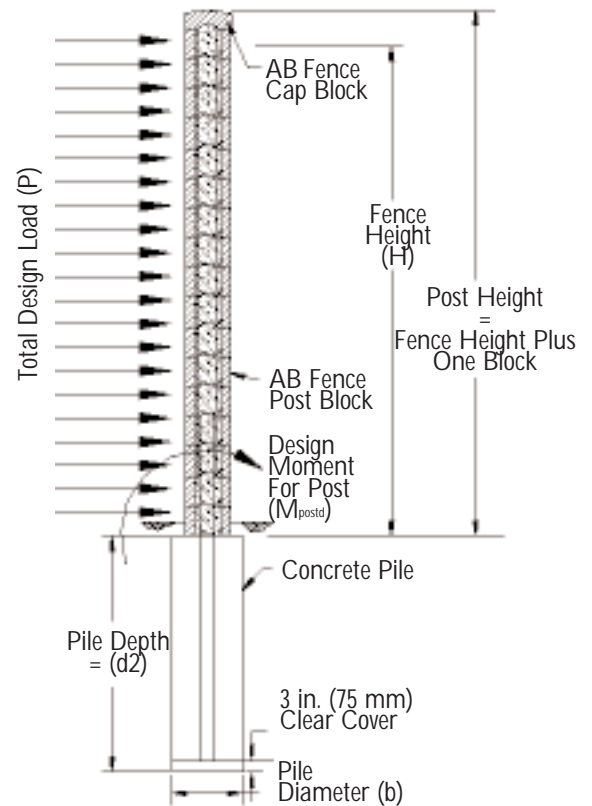

## **Design Example**

Determine the resisting moments due to Selfweight of Post, Panel and Footing:

Weight of Panel Block ( $w_{t_{panel}}$ )	= 47 lb (209.07 N)
Weight of Post Block ( $w_{t_{post}}$ )	= 70 lb (311.38 N)
Weight of Cap unit ( $w_{t_{cap}}$ )	= 60 lb (266.89 N)
Weight of grout per Panel Block ( $w_{t_{panelg}}$ )	= 14.4 lb (64.05 N)
Weight of concrete per Post Block ( $w_{t_{postc}}$ )	= 48 lb (213.51 N)

$$\begin{aligned} \text{Total weight of Post} &= (Z^{post})(w_{t_{post}} + w_{t_{postc}}) + w_{t_{cap}} \\ &= (13)(70 \text{ lb} + 48 \text{ lb}) + 60 \text{ lb} \\ &= 1594 \text{ lb (7090.4 N)} \end{aligned}$$

$$\begin{aligned} \text{Total weight of Panel} &= (Z^{panel})(s)(w_{t_{panel}}) + (w_{t_{cap}})(s) \\ &= (12)(9)(47 \text{ lb}) + (60 \text{ lb})(9) \\ &= 5616 \text{ lb (24981.2 N)} \end{aligned}$$

Weight of Bond Beam (bb) grout:

$$\begin{aligned} \# \text{ of grouted course} &= (N_{bb})(2 \text{ course per Bond Beam}) \\ &= (2)(2) = 4 \\ \text{wt of bb grout} &= (4)(s)(w_{t_{panelg}}) \\ &= (4)(9)(14.4 \text{ lb}) \\ &= 518.4 \text{ lb (2306.0 N)} \end{aligned}$$

$$\text{Total weight of Panel} = 5616 \text{ lb} + 518.4 \text{ lb} = 6134.4 \text{ lb (27293.6 N)}$$

Estimate Footing weight:

$$\begin{aligned} \text{Diameter (b)} &= 2 \text{ ft (0.610 m)} \\ \text{Estimated depth (d}_2\text{)} &= 4.5 \text{ ft (1.37 m)} \\ \text{Est. Wt of Footing} &= (\pi)(b / 2)^2 (d_2)(wc) \\ &= (\pi)(2 \text{ ft} / 2)^2(4.5 \text{ ft})(135 \text{ pcf}) \\ &= 1908 \text{ lb (8487.2 N)} \end{aligned}$$

$$wc = \text{unit weight of concrete} = 135 \text{ pcf (2162.5 kg/m}^3\text{)}$$

## Design Example

Determine the total resistance moments due to the weight of the post, panel and footing:

$$\begin{aligned}
 \text{Post:} \quad M_{\text{swpost}} &= (\text{wt of post})(P_d / 2) \\
 &= (1594 \text{ lb}) \left( \frac{11.625 \text{ in}/12 \text{ (in/ft)}}{2} \right) \\
 &= 772.1 \text{ lb-ft (1046.83 N-m)}
 \end{aligned}$$

NOTE: The moment arm for the post is the width of the post ( $P_d$ ) divided by 2.

$$\begin{aligned}
 \text{Panel:} \quad M_{\text{swpanel}} &= (\text{wt of panel})(t / 2) \\
 &= (6134.4 \text{ lb}) \left( \frac{5.628 \text{ in}/12 \text{ (in/ft)}}{2} \right) \\
 &= 1438.5 \text{ lb-ft (1950.34 N-m)}
 \end{aligned}$$

NOTE: The moment arm for the panel is the width of the panel ( $t$ ) divided by 2.

$$\begin{aligned}
 \text{Footing:} \quad M_{\text{swfooting}} &= (\text{wt of footing})(P_d / 2) \\
 &= (1908 \text{ lb}) \left( \frac{[11.625 \text{ in}/12 \text{ (in/ft)]}}{2} \right) \\
 &= 924.2 \text{ lb-ft (1253.05 N-m)}
 \end{aligned}$$

NOTE: The equivalent moment arm for the footing can be estimated similar to that of the post, therefore ( $P_d$ ) divide by 2.

Design Moment for Post design

$$\begin{aligned}
 M_{\text{postdesign}} &= M_{\text{postd}} - (0.9)(M_{\text{swpost}} - M_{\text{swpanel}}) \\
 &= 5154.1 \text{ lb-ft} - (0.9)(772.1 \text{ lb-ft} + 1438.85 \text{ lb-ft}) \\
 &= 3164.2 \text{ lb-ft (4290.1 N-m)}
 \end{aligned}$$

NOTE: The AB Fence post capacity must be greater than this value.

Design Moment for Footing design

$$\begin{aligned}
 M_{\text{footingdesign}} &= M_{\text{paneld}} - (0.9)(M_{\text{swpost}} - M_{\text{swpanel}} - M_{\text{swfooting}}) \\
 &= 5117.1 \text{ lb-ft} - (0.9)(772.1 \text{ lb-ft} + 1438.85 \text{ lb-ft} + 924.2 \text{ lb-ft}) \\
 &= 2295.5 \text{ lb-ft (3112.28 N-m)}
 \end{aligned}$$

NOTE: This value will be used for determining design depth of the post footing.

## Design Example

### Compressive Strength Calculations

Allowable moment capacity based on compressive strength of masonry for the post ( $M_{cp}$ ):

$$M_{cp} = \frac{(f_b)(b_s)(d_s^2)(j)(k)}{2}$$

Compressive strength:

$$f_m = 3000 \text{ psi} \quad (20.68 \text{ MPa})$$

NOTE: This is the minimum allowable compressive stress of the block units based on ASTM 1372. If the tested values show a greater strength the designer may choose to use the higher tested value.

The allowable compressive strength for masonry design:

$$\begin{aligned} f_b &= (0.333)(f_m) \\ &= 1000 \text{ psi} \quad (6.89 \text{ MPa}) \end{aligned}$$

Post section dimensions are based on the rectangular section of the block depth and block length which does not include the wings.

Post section length ( $b_s$ ):

$$\begin{aligned} b_s &= P_l - (2)(P_{nd}) \\ &= 17.625 \text{ in} - (2)(1.5 \text{ in}) \\ &= 14.625 \text{ in} \quad (371.5 \text{ mm}) \end{aligned}$$

Distance to tension steel ( $d_s$ ):

$$\begin{aligned} d_s &= P_d - 2.25 \text{ in} - 1 \text{ in clr} - \text{bar dia.} \\ &= 8.06 \text{ in} \quad (204.7 \text{ mm}) \end{aligned}$$

$j$  and  $k$  are coefficients used for internal moments and definitions of the neutral axis.

$$\begin{aligned} k &= \left\{ \left[ (n)(\rho) \right]^2 + (2)(n)(\rho) \right\}^{0.5} - (n)(\rho) \\ j &= 1 - \frac{k}{3} \end{aligned}$$

Ratio of reinforcing steel in post section:

$$\rho = \frac{(A_s / 2)}{(b_s)(d_s)}$$

NOTE:  $A_s / 2$  because only the tension steel is used.

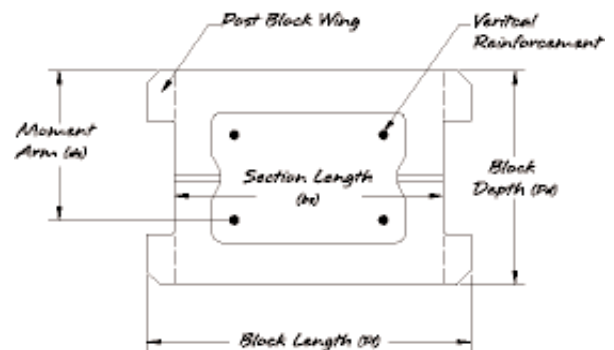

## Design Example

### Compressive Strength Calculations

Area of steel in post section ( $A_s$ ):

$$\begin{aligned} \text{Area of bar (} A_b \text{)} &= (\pi)(r^2) \\ &= 0.307 \text{ in}^2 \quad (198.1 \text{ mm}^2) \end{aligned}$$

$$\begin{aligned} A_s &= (A_b)(\# \text{ of bars in post}) \\ &= (0.307)(4) = 1.227 \text{ in}^2 \quad (791.61 \text{ mm}^2) \end{aligned}$$

Therefore:

$$\begin{aligned} \rho &= \frac{A_s / 2}{(bs)(ds)} \\ &= \frac{1.227 \text{ in}^2 / 2}{(14.625 \text{ in})(8.06 \text{ in})} \\ &= 0.0052 \end{aligned}$$

$n$  is the modular ratio and is calculated using the modulus of elasticity of the composite materials:

$$n = E_s / E_m$$

$E_s$  is the modulus of elasticity of for nonprestressed steel:

$$E_s = 29000 \text{ ksi} \quad (200,000 \text{ MPa})$$

$E_m$  is the modulus of elasticity of masonry, commonly taken as:

$$\begin{aligned} E_m &= (900)(f_m) \\ &= (900)(3000 \text{ psi}) \\ &= 2700 \text{ ksi} \quad (18,615.8 \text{ MPa}) \end{aligned}$$

Therefore:

$$\begin{aligned} n &= 29000 \text{ ksi} / 2700 \text{ ksi} \\ &= 10.741 \end{aligned}$$

Therefore:

$$\begin{aligned} k &= \{[(n)(\rho)]^2 + (2)(n)(\rho)\}^{0.5} - (n)(\rho) \\ &= \{[(10.741)(0.0052)]^2 + (2)(10.741)(0.0052)\}^{0.5} - (10.741)(0.0052) \\ &= 0.2830 \end{aligned}$$

and:

$$j = 1 - \frac{k}{3}$$

$$= 1 - \frac{0.2830}{3}$$

$$= 0.9057$$

$$\begin{aligned} M_{cp} &= \frac{(f_b)(bs)(ds^2)(j)(k)}{2} \\ &= \frac{(1000 \text{ psi})(14.625 \text{ in}/12 \text{ in/ft})(8.06^2 \text{ in}^2)(0.9057)(0.283)}{2} \\ &= 10157 \text{ lb-ft} \quad (13,771 \text{ N-m}) \end{aligned}$$

At this point the Work Energy factor is put into the equations, from Table 1.4.

$$\begin{aligned} M_{cp} &= (P_e r)(10157 \text{ lb-ft}) \\ &= (1.45)(10157 \text{ lb-ft}) \\ &= 14728 \text{ lb-ft} \quad (19,968.5 \text{ N-m}) \end{aligned}$$

This is the allowable moment capacity for this post section and can than be compared to the design applied moment ( $M_{\text{post design}}$ ) of 3164.2 lb-ft (4290.1 N-m). The moment capacity is much greater than the applied moment therefore this section is safe to use.

## Design Example

### Compressive Strength Calculations

Allowable Moment capacity based on compressive strength of masonry for the bond beam ( $M_{C_{bb}}$ ):

$$M_{C_{bb}} = \frac{(f_b)(b_{bb})(d_{bb}^2)(j_{bb})(k_{bb})}{2}$$

Bond beam section length ( $b_{bb}$ ):

$$\begin{aligned} b_{bb} &= (2)(h) = (2)(7.625 \text{ in}) \\ &= 15.25 \text{ in} \quad (387.35 \text{ mm}) \end{aligned}$$

Distance to tension steel ( $d_{bb}$ ):

$$\begin{aligned} d_{bb} &= t / 2 = 5.628 \text{ in} / 2 \\ &= 2.814 \text{ in} \quad (71.48 \text{ mm}) \end{aligned}$$

$j$  and  $k$  are coefficients used for internal moments and definitions of the neutral axis.

$$\begin{aligned} k_{bb} &= \{[(n)(\rho_{bb})]^2 + (2)(n)(\rho_{bb})\}^{0.5} - (n)(\rho_{bb}) \\ j_{bb} &= 1 - \frac{k_{bb}}{3} \end{aligned}$$

Ratio of reinforcing steel in bond beam section:

$$\rho_{bb} = \frac{A_{bb}}{(b_{bb})(d_{bb})}$$

Area of steel in bond beam section ( $A_{bb}$ ):

$$\begin{aligned} \text{Area of bar } (A_b) &= (\pi)(r^2) \\ &= 0.196 \text{ in}^2 \quad (126.45 \text{ mm}^2) \\ A_{bb} &= (A_b)(\# \text{ of bars in bond beam}) \\ &= (0.196)(1) = 0.196 \text{ in}^2 \quad (126.45 \text{ mm}^2) \end{aligned}$$

$$\begin{aligned} \text{Therefore: } \rho_{bb} &= \frac{A_{bb}}{(b_{bb})(d_{bb})} \\ &= 0.196 \text{ in}^2 / [(15.25 \text{ in})(2.814 \text{ in})] \\ &= 0.0046 \end{aligned}$$

$$\begin{aligned} \text{Therefore: } k_{bb} &= \{[(n)(\rho_{bb})]^2 + (2)(n)(\rho_{bb})\}^{0.5} - (n)(\rho_{bb}) \\ &= \{[(10.741)(0.0046)]^2 + (2)(10.741)(0.0046)\}^{0.5} - (10.741)(0.0046) \\ &= 0.2682 \end{aligned}$$

$$\begin{aligned} \text{and: } j_{bb} &= 1 - \frac{k_{bb}}{3} \\ &= 1 - \frac{0.2682}{3} \\ &= 0.9106 \end{aligned}$$

$$\begin{aligned} M_{C_{bb}} &= \frac{(f_b)(b_{bb})(d_{bb}^2)(j_{bb})(k_{bb})}{2} \\ &= \frac{(1000 \text{ psi})(15.25 \text{ in}/12 \text{ in/ft})(2.814^2 \text{ in}^2)(0.9106)(0.2682)}{2} \\ &= 1228.8 \text{ lb-ft} \quad (1666.0 \text{ N-m}) \end{aligned}$$

At this point the added strength from the ball and socket configuration is put into the equations equal to a 1.5 multiplier.

$$\begin{aligned} M_{C_{bb}} &= (1.5)(1228.8 \text{ lb-ft}) \\ &= 1843.1 \text{ lb-ft} \quad (2498.9 \text{ N-m}) \end{aligned}$$

This is the allowable moment capacity for this bond beam section and can then be compared to the design applied moment ( $M_{\text{panel d}}$ ) of 1171.25 lb-ft (1588.0 N-m). The moment capacity is much greater than the applied moment therefore this section is safe to use.

## **Design Example**

### Tensile Stress Calculations

Allowable moment capacity based on tensile stress of reinforcement in the Post (M<sub>tp</sub>):

$$M_{tp} = (f_s)(A_s / 2)(j)(d_s)$$

Yield stress (f<sub>y</sub>) in reinforcing steel is commonly known as 60 ksi (413.68 MPa) but the allowable tensile stress is 40% of the yield. Therefore:

$$\begin{aligned} f_y &= 60 \text{ ksi (413.68 MPa)} \\ f_s &= (0.4)(f_y) = (0.4)(60) = 24 \text{ ksi (165.47 MPa)} \end{aligned}$$

Therefore:

$$\begin{aligned} M_{tp} &= (f_s)(A_s / 2)(j)(d_s) \\ &= (24000 \text{ psi})(1.227 \text{ in}^2 / 2)(0.9057)(8.06) \\ &= 8961.3 \text{ lb-ft (12,149.89 N-m)} \end{aligned}$$

At this point the Work Energy Factor (per) is put into the equations, from Table 1.4, on Page 7.

$$\begin{aligned} M_{tp} &= (\text{Per})(8961.3 \text{ lb-ft}) \\ &= (1.45)(8961.3 \text{ lb-ft}) \\ &= 12994 \text{ lb-ft (17,617.5 N-m)} \end{aligned}$$

This is the allowable moment capacity for this post section and can then be compared to the design applied moment (M<sub>post design</sub>) of 3164.2 lb-ft (4290.1 N-m). The moment capacity is much greater than the applied moment therefore this section is safe to use.

Allowable Moment Capacity based on Tensile Stress of reinforcement in the Bond Beam:

$$\begin{aligned} M_{t_{bb}} &= (f_s)(A_{bb})(j_{bb})(d_{bb}) \\ &= (24000 \text{ psi})(0.196 \text{ in}^2)(0.9106)(2.814) \\ &= 1006.3 \text{ lb-ft (1364.36 N-m)} \end{aligned}$$

At this point the added strength from the ball and socket configuration is put into the equations equal to a 1.5 multiplier.

$$\begin{aligned} M_{t_{bb}} &= (1.5)(1006.3 \text{ lb-ft}) \\ &= 1509.4 \text{ lb-ft (2046.47 N-m)} \end{aligned}$$

This is the allowable moment capacity for this bond beam section and can then be compared to the design applied moment (M<sub>panel d</sub>) of 1171.25 lb-ft (1588.0 N-m). The moment capacity is much greater than the applied moment therefore this section is safe to use.

## Design Example

### Concrete Shear Calculations

All structural calculations contain a required section on shear but with the AB Fence system shear is not the limiting factor in design and you will see that the capacities far exceed the design requirements. Shear is simply the action of breaking the structural member lateral to its flexural steel. In the AB Fence calculations a designer should check the shear capacity of the post where it intersects with the footing and the shear capacity of the panel where it intersects with the post.

#### Post Section Calculations

Allowable shear stress in reinforced masonry is commonly accepted to be conservative at:

$$S_{ssa} = 55 \text{ psi (379.2 kPa)}$$

Calculate the shear stress at the base of the pilaster.

$$\begin{aligned} S_{req} &= \frac{(P)(Ta)}{(bs)(ds)} \\ &= \frac{(11.15 \text{ psf})(115.825 \text{ ft}^2)}{(14.625 \text{ in})(8.06 \text{ in})} \\ &= 10.96 \text{ psi (75.57 kPa)} \ll 55 \text{ psi (379.2 kPa)} \quad \text{"OK"} \end{aligned}$$

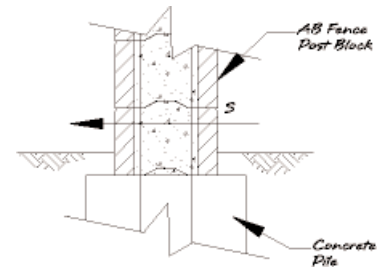

#### Panel Section Calculations

For the panel section we consider the force applied over the entire panel then divide by 2 to localize the force to one post block wing. The allowable wing shear is based on the available area of the post block wing. Independent laboratory testing gave an average strength of 2779 lb/block wing (12.36 kN). We will apply a safety factor of 3 to the calculations.

Allowable wing shear:

$$S_{wing} = \frac{2779 \text{ lb}}{(3)(h)}$$

$$S_{wing} = 1457 \text{ lb/ft (21.27 kN/m)}$$

The calculated shear at each wing is as follows:

Area of the Panel only:

$$\begin{aligned} A_{wpanel} &= (H)(P_s - P_l) \\ &= (7.98 \text{ ft})(14.51 \text{ ft} - 1.4688 \text{ ft}) \\ &= 104.1 \text{ ft}^2 (9.67 \text{ m}^2) \end{aligned}$$

The applied shear:

$$\begin{aligned} S_{wreq} &= \frac{(0.5)(P)(A_{wpanel})}{H} \\ &= \frac{(0.5)(11.15 \text{ psf})(104.1 \text{ ft}^2)}{7.98 \text{ ft}} \end{aligned}$$

$$= 73 \text{ lb/ft (1061 N/m)} \ll S_{wing} = 1457 \text{ lb/ft (21.27 kN/m)} \quad \text{"OK"}$$



## Design Example

### Footing Design

The foundation for the AB Fence system in this manual is a basic 2 ft (0.61m) diameter concrete pile. Using the following equation and an iterative process a footing depth can be obtained.

On page 13, we estimated the size of the footing and determined a weight of footing to calculate a resistance due to its selfweight. Using the footing's selfweight we calculated a design moment for footing design ( $M_{\text{footing design}}$ ).

$$\begin{aligned}
 P1 &= \frac{M_{\text{footing design}}}{(0.5)(H)} \\
 &= \frac{2295.5 \text{ lb-ft}}{(0.5)(7.98 \text{ ft})} \\
 &= 584.36 \text{ lb (2.6 kN)}
 \end{aligned}$$

Where P1 is the footings design moment translated into its force vector at the mid height of the panel.

The required depth is determined by the following equation:

$$d = \left( \frac{A}{2} \right) \left( 1 + \sqrt{1 + \frac{4.36h_1}{A}} \right)$$

where:  $A = \frac{(2.34)(P1)}{(S_{\text{factored}})(d_2)(b)} = 2.279 \text{ ft (0.69 m)}$

And:  $h_1 =$  the distance in feet from the ground surface to the point of application of P1

$$= H / 2 = 3.99 \text{ ft (1.22 m)}$$

Therefore:  $d = \left( \frac{2.279 \text{ ft}}{2} \right) \left( \sqrt{1 + \frac{(4.36h_1)(3.99\text{ft})}{2.279 \text{ ft}}} \right)$   
 $= 4.488 \text{ ft (1.37 m)} < 4.5 \text{ ft (1.37 m)} \quad \text{"OK"}$

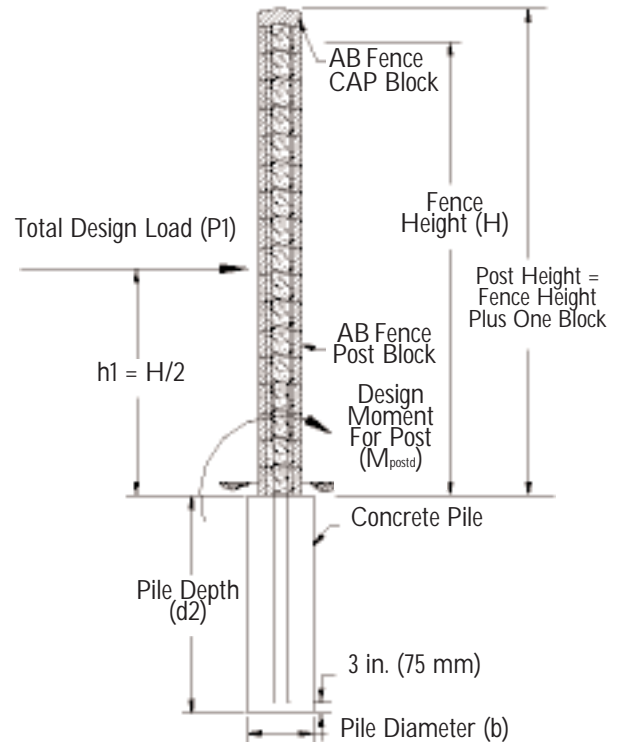

## Soil Retention

The Allan Block Fence system is capable of retaining soil as long as the designer accounts for the additional lateral forces the retained soil exerts on the system. Small levels of retention can be worked into the example above by simply calculating the lateral earth pressure and applying it to the Post overturning moments. Please note that all courses associated with soil retention must be constructed as bond beams, with horizontal steel, sand-mix grout and vertical stirrups. The rigid nature of the bond beams will transfer all soil forces to the posts and footing. During the soil retention design the designer may need to reduce the post spacing to meet the capacity of the pilasters.

For this example we will assume the following for soil retention and soil parameters:

Soil height	Hs	= 3 ft (0.91 m)
Internal Friction Angle	$\phi_i$	= 30 degrees
Unit Weight of soil	$\gamma_i$	= 120 pcf (19 kN/m <sup>3</sup> )

For a more in depth review of soil retention and associated methodologies review the Engineering Manual for Allan Block Wall Systems.

Calculations for static lateral earth pressure coefficient (Ka):

Wall Batter	$\beta$	= 90 degrees
Weighted Friction Angle	$\phi_{wi}$	= (2/3)( $\phi_i$ ) = 20 degrees

$$K_a = \left[ \frac{\csc(\beta) \sin(\beta - \phi_i)}{\sqrt{\sin(\beta + \phi_{wi})} + \sqrt{\frac{\sin(\phi_i + \phi_{wi}) \sin(\phi_i - i)}{\sin(\beta - i)}}} \right]^2$$

Where  $i$  = back slope angle

NOTE: typically in AB Fence projects the back slope would equal zero or fall away for drainage.

Active Earth Force:  $F_a = (0.5)(K_a)(\gamma_i)(H_s^2)$   
 $= 160.55 \text{ lb/ft (2343.0 N/m)}$

Because the soil is applying the lateral force, it is split into horizontal and vertical force vectors but we ignore the vertical component because it does not apply force directly to the wall.

Horizontal force:  $F_{ah} = (F_a)[\cos(f_w)]$   
 $= 150.87 \text{ lb/ft (2201.7 N/m)}$

Determine the overturning moment due to soil retention (Mah):

$$M_{ah} = (F_{ah})(P_s) (H_s / 3)$$

$$= 2189.22 \text{ lb-ft (2968.2 N-m)}$$

This value would then be added to the wind overturning forces and applied to the post structure.

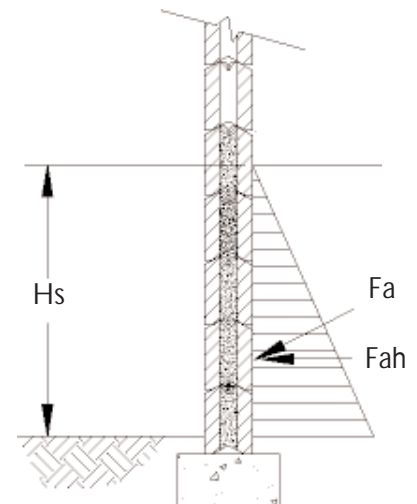

## Soil Retention

For AB Fence structures with surcharges above the retained portion such as sidewalks the design process is similar to the lateral earth pressure calculations. You must first determine the horizontal force vector for the surcharge.

Surcharge Force:  $F_q = (q)(K_a)(H_s)$   
 Where:  $q$  = the Live Load Surcharge.

For this example:  $q = 100 \text{ psf (4.8 kPa)}$   
 Therefore:  $F_q = 89.19 \text{ lb/ft (1301.7 N/m)}$   
 Horizontal force:  $F_{qh} = (F_q)[\cos(\phi_{vi})]$   
 $= 83.8 \text{ lb/ft (1223.2 N/m)}$

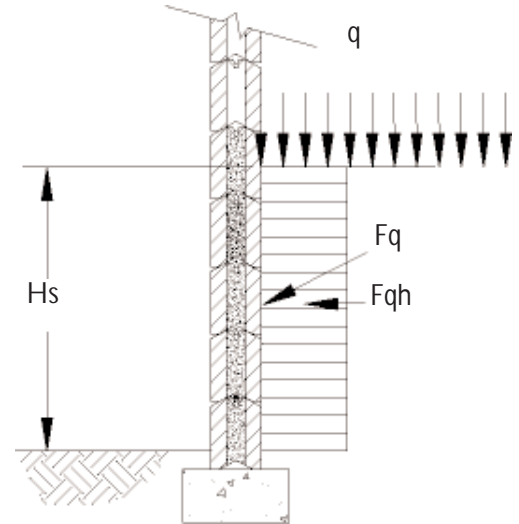

Determine the overturning moment due to surcharge above soils retention ( $M_{qh}$ ):

$$M_{qh} = (F_{qh})(P_s)(H_s / 2)$$

$$= 1824.4 \text{ lb-ft (2473.5 N-m)}$$

This value would then be added to the wind overturning force and applied to the post structure.

## Soil Retention with a Geogrid Reinforced Mass

A designer can greatly increase the amount of soil retention using a geogrid reinforced mass behind the AB Fence. Reinforced soil masses can be constructed to do all the work in retaining soil. As with an Allan Block retaining wall the geogrid reinforced soil mass develops enough weight to resist the applied forces from the retained soils and surcharges. The designer can design a mass sufficient to resist all applied loads and transfer a very small amount of force to the AB Fence structure.

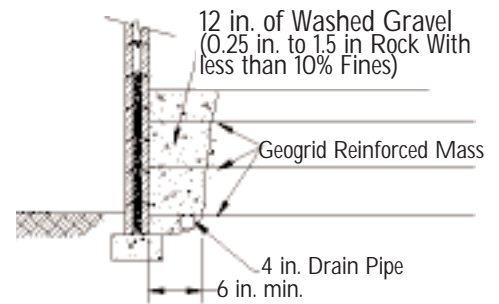

Geogrid Reinforced Mass

There are two ways to construct a reinforced mass. The first is to build the entire fence in place and then backfill the retained side in no more than 8 in. (200 mm) lifts, placing the design lengths of geogrid in at the design location, not to exceed 16 in. (400 mm) spacing. The first 12 inches of infill soil up against the fence must be washed gravel to promote drainage behind the fence and must be compacted after each lift of soil is placed. In this type, the geogrid would butt up to the back side of the fence and make no physical connection to the fence. The only forces transferred to the fence are minor compaction forces during construction.

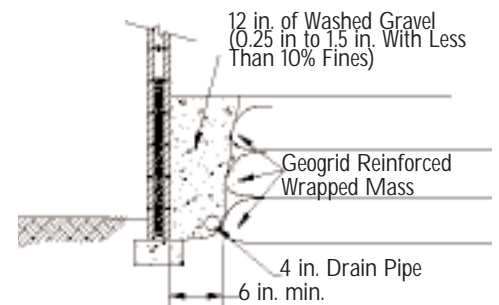

Geogrid Reinforced Wrapped Mass

The second way is the reinforced mass is constructed prior to the fence as a Geogrid Reinforced Wrapped Mass. After the fence is constructed the only forces applied to the fence is the bin pressure of the washed gravel placed between the fence and the wrapped mass face.



# **APPENDIX 1:**

## **Intermediate Column & Other Constructability Enhancements**

### **Intermediate Column**

During Full-Scale Panel Flexural Testing of longer panels, an aesthetic issue of large deflections at the center of the panel was noticed under extreme loads. As the loads increased on the panel, the center of the panel started to bulge out. This bulge would not completely rebound even though the bond beams would rebound to their initial conditions once the loads were removed. The center column is simple to construct since it consists of adding a single vertical rebar running through the cores of the dry stacked panel block. These vertical cores are then filled with a fine sand-mixed concrete grout matching that used in the bond beam. It is not required to have the intermediate column extend into the bond beams located above or below. During testing, when the center column was added the bulge was eliminated after the loads were removed and the panel rebounded. It was also recorded that the load transfer to the posts was not affected by adding the center column. Since the large deflections were only noticed on the longer panel spacing, it is Allan Block's recommendation that the intermediate column (Figure 12) be used only in panels with a post spacing greater than 15 feet long (4.6 m).

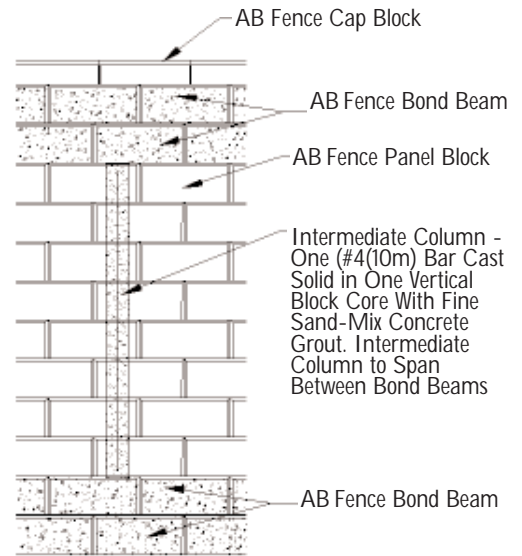

**Figure 12 :  
Intermediate Columns**

### **Unreinforced Leveling Pad**

The AB Fence system requires a leveling pad be placed prior to construction of the panel. The typical leveling pad is a compacted aggregate pad. Some contractors may choose to construct an unreinforced concrete leveling pad (Figure 13) instead of the compacted aggregate pad. An unreinforced concrete leveling pad can aid the contractor in leveling the base course, especially in longer panels. Allan Block would recommend the use of an unreinforced concrete leveling pad in fences with post spacings exceeding 15 ft (4.57 m) long but one could be used in all AB Fence application if the contractor chose.

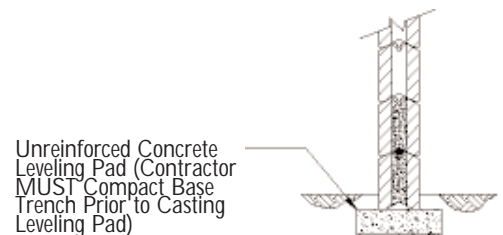

**Figure 13 :  
Unreinforced Concrete Leveling Pad**



## **REFERENCES**

*International Building Code (IBC) 2000*

*American Society of Civil Engineers (ASCE)*

*Minimum Design Loads for Buildings and Other Structures Revision of ASCE 7-98*

*American Association of State Highway and Transportation Officials (AASHTO)*

*AASHTO, Guide Specifications for Structural Design of Sound Barriers (1989)*

*FHWA Highway Noise Barrier Design Handbook*

*The Civil Engineering Handbook, W. F. Chen, (1995)*

*Reinforced Concrete Mechanics and Design, James G. MacGregor (1988)*

*NRC-CNRC, National Building Code of Canada, (1995)*

*CAN/CSA-S6-00, Canadian Highway Bridge Design Code*

*S6.1-00, Commentary on CAN/CSA-S6-00, Canadian Highway Bridge Design Code*

*Manual of Steel Construction, Load and Resistance Factor Design (1986)*

*First Edition for Beam Diagrams and Formulas in Static Load Conditions*

*AB Fence Testing Manual - F0205*

*AB Fence Install Guide - F0501*

*ABC/Stork TCT 4.0' - 8.0' x 11.5' Solid Spreader Frame Test*

*ABC/Stork TCT 8.0' x 11.5' Articulating Frame Test*

*ABC/Stork TCT 8.0' x 17.6' Articulating Frame Test*

*ABC/Stork TCT 8.6' AB Fence Post Flexural Test*



## ***Additional Resources***

Visit our web site at [allanblock.com](http://allanblock.com) for the latest information on the AB Fence system. Check out our:

Installation Guide and Tech Sheets

Estimating Tool

Product Testing Results

Design Details

Project Photography

and much more...

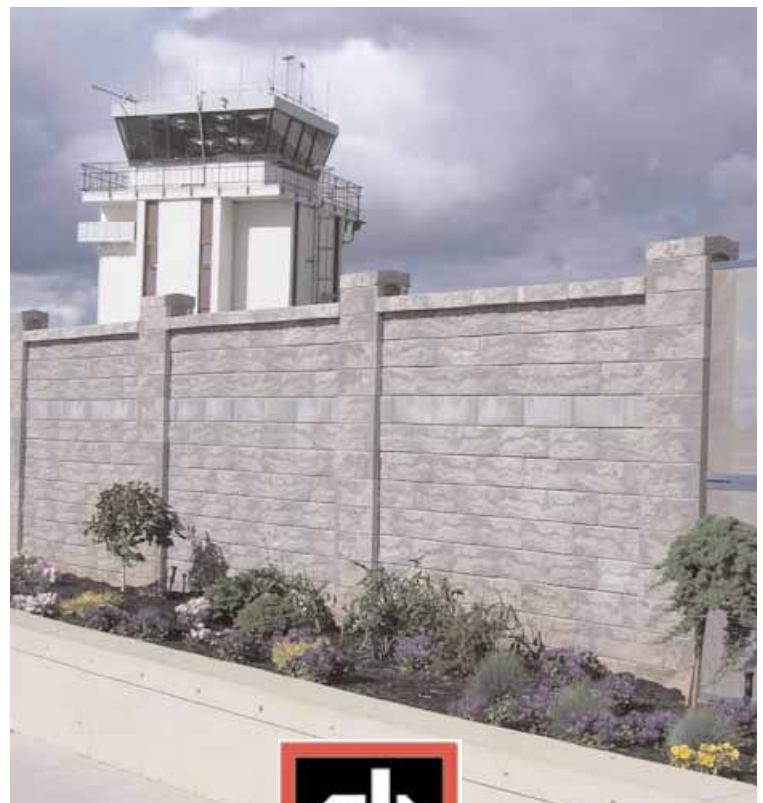

[allanblock.com](http://allanblock.com)

For more information on AB Fence visit our web site or call the  
Allan Block Engineering Department at 800-899-5309.



[allanblock.com](http://allanblock.com)